

Specifications	
Description	Free standing unit eliminates the need for floor pits and ramps.
Materials	304 grade stainless steel
Bin Type	200 litre eurobins (DIN 9797)
Option	120L With additional adaptor brackets
Capacity	250kg
Power supply	Universal power supply: 85 to 264 V AC single phase. 49 to 61Hz, 13 amp
Operating environment temperature	-10°C to 40°C
Indicator type	Mettler Toledo digital indicator - See comparison table for options available
Controls	Manual lever linkage
Mass	100kg

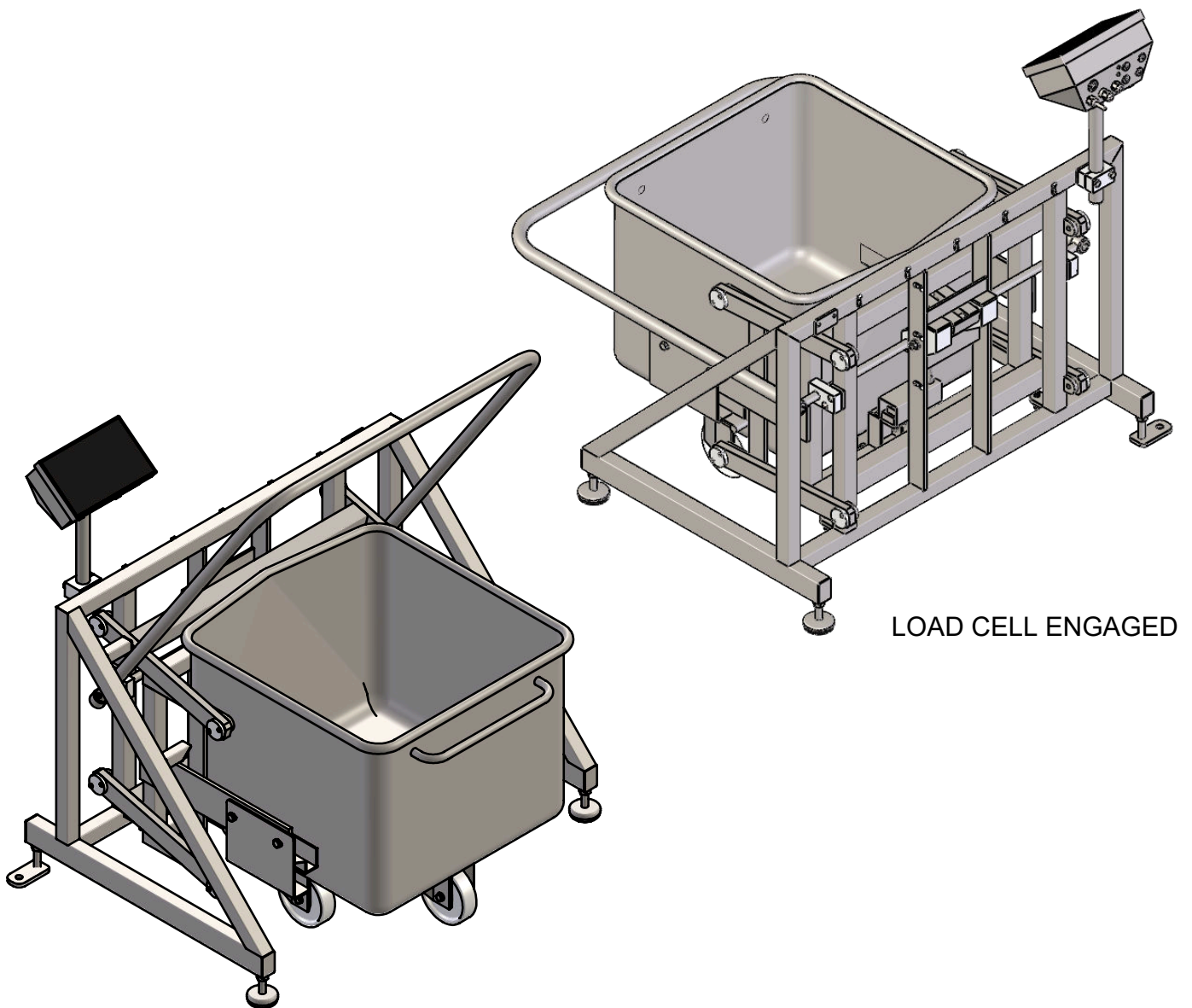

LOAD CELL DISENGAGED

LOAD CELL ENGAGED

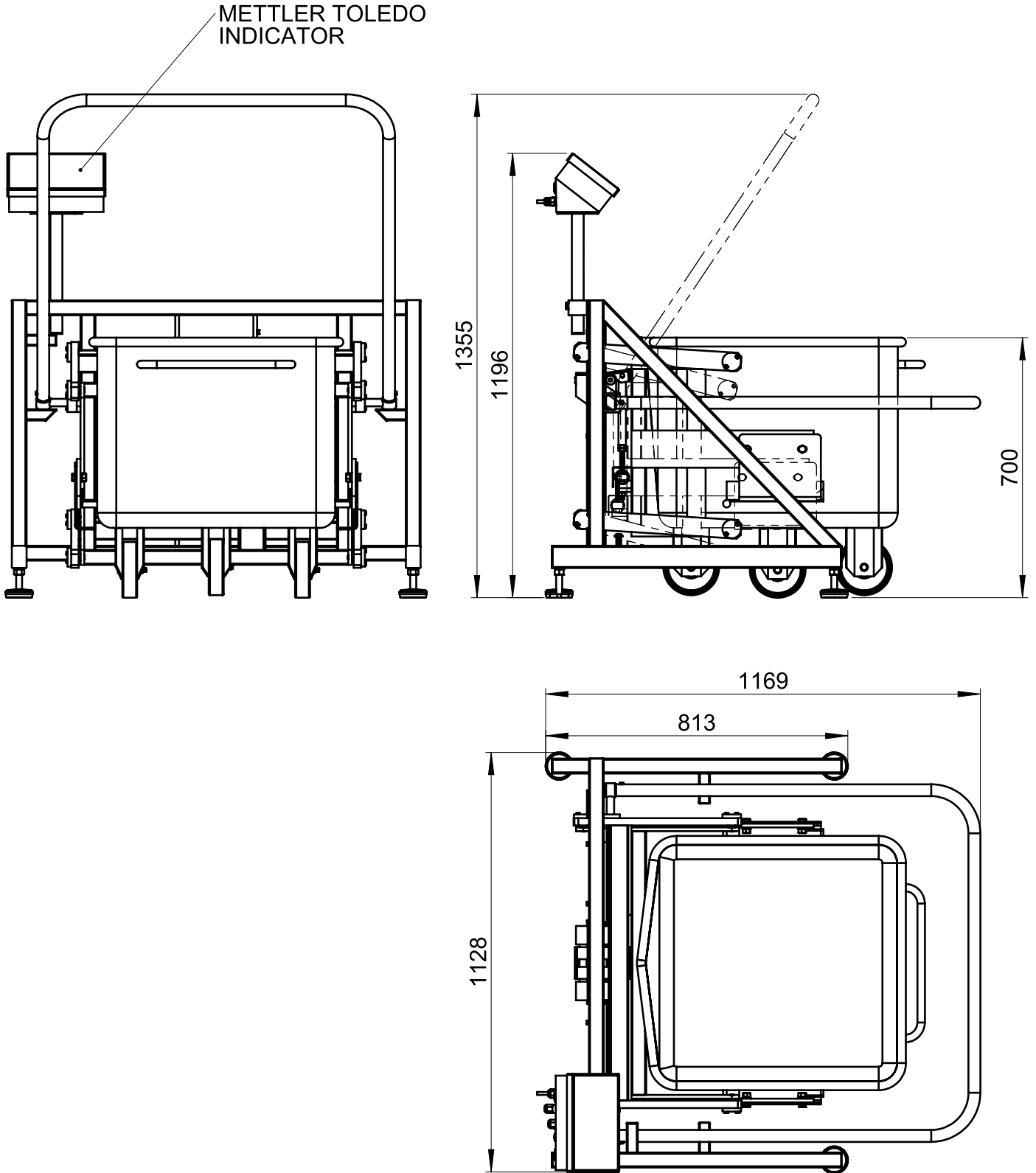

SYSPAL LTD Cockshutt Lane, Broseley, Telford, Shropshire, TF12 5JA, England

t: +44 (0) 1952 883188 f: +44 (0) 1952 884093 e: [sales@sypal.com](mailto:sales@sypal.com)

[www.sypal.com](http://www.sypal.com)